

Service training

Flowmate Control

FMC-R

+

Special part

HC-boom

function of pressure restriction valves 11/02

subject to change











**Kverneland Nieuw-Vennep B.V.
Hoofdweg 1278
NL-2153 LR Nieuw-Vennep
The Netherlands**

The logo for RAU, consisting of the letters "RAU" in a bold, italicized, sans-serif font.

Content:

Colours	1
Control box FMC-R	2
Elements of FMC-R	3
Power cable	
CAN - cable	
Splitter box	4
SHC – box (connection)	5
Connection	
Position and connection of section cables	6
Relay at section valve motor	
Position of hydraulic cables	7
Example 1	
Example 2	
HC - standard	
HC with oil circulation	
Connection of hydraulic cables	8
Hydraulic cables	9
Control box	10
Connector CAN - plug & speed- / radar sensor (tractor)	
Front cover inside	11
Setup menu	12
Pin	14
Activate hydraulic switches	15
Change hydraulic switch settings	
Setup menu continued from last page	
Control box tests	18
Display and switches	
Switch test	
Button test	
Sensor input test	
Buzzer test	
Display test	
LED test	
SHC – box test	19
standard	
+ (plus 12V) test	
– (minus) test:	20
„S“ signal test	
Cable and sensor test	21
Cable test	
Speed sensor (machine) and locking sensor test	22
Speed sensor	
Locking sensor	
Flow sensor test	
Special alarm functions	23
!H + !S	
Special tools	24
Plugs	25
List special tools & special material (electronic spare parts)	26
Special part HC boom (Folding in / out)	27
Folding in (cylinders will be moved to longest length)	
Folding out (cylinders will be moved to shortest length)	29

colours

	English	deutsch	français
	yellow	gelb	jaune
	orange	orange	orange
	red	rot	rouge
	green	grün	vert
	blue	blau	bleu
	black	schwarz	noir
	brown	braun	brun
	white	weiß	blanc
	grey	grau	gris
	yellow / black	gelb / schwarz	jaune / noir
	white / black	weiß / schwarz	blanc / noir
	grey / red	grau / rot	gris / rouge
	white / blue	weiß / blau	blanc / bleu

control box FMC-R

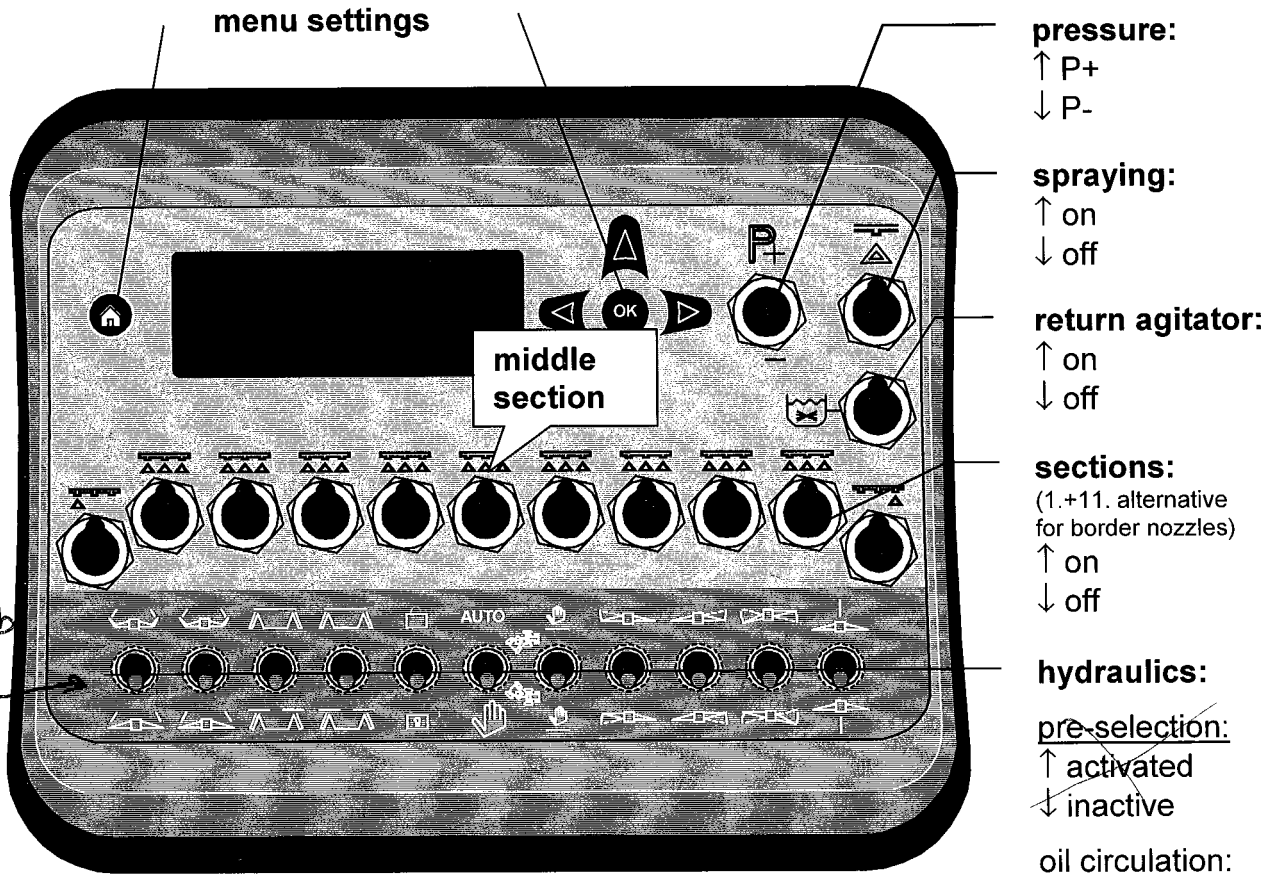

Burgers
DIS

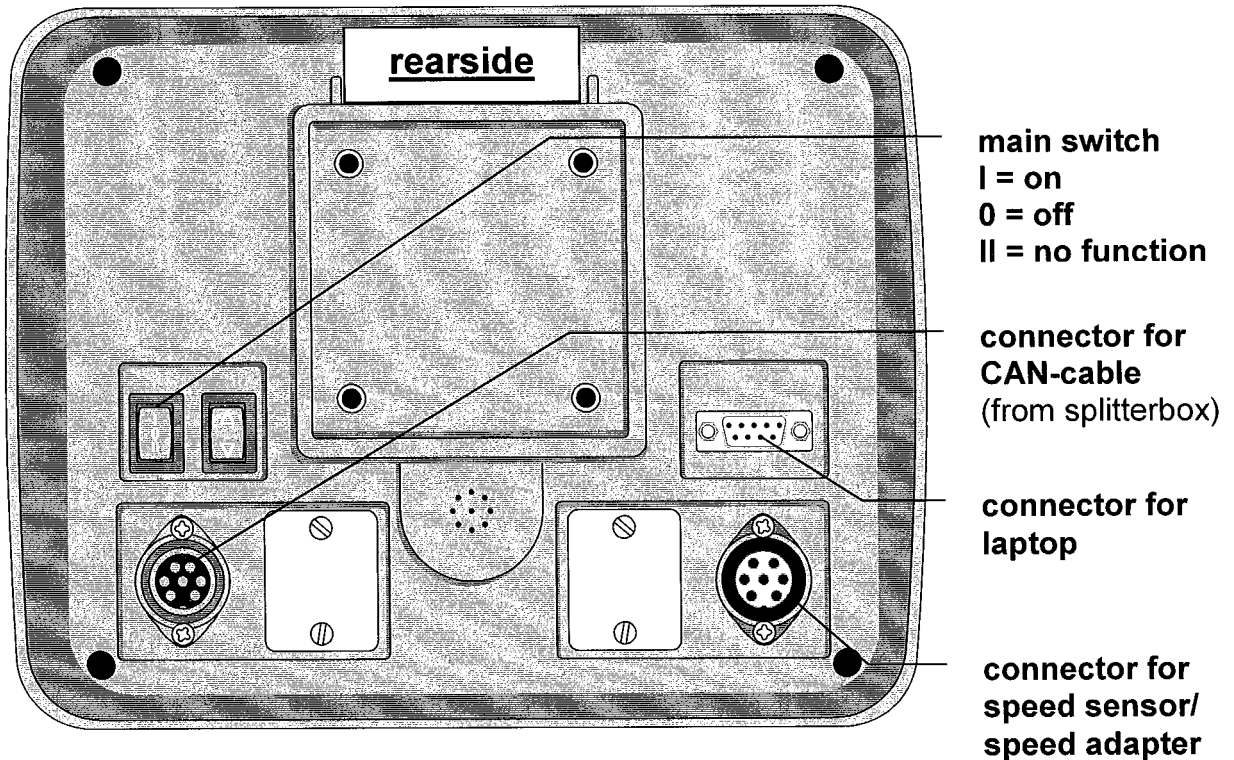

rou

elements of FMC-R

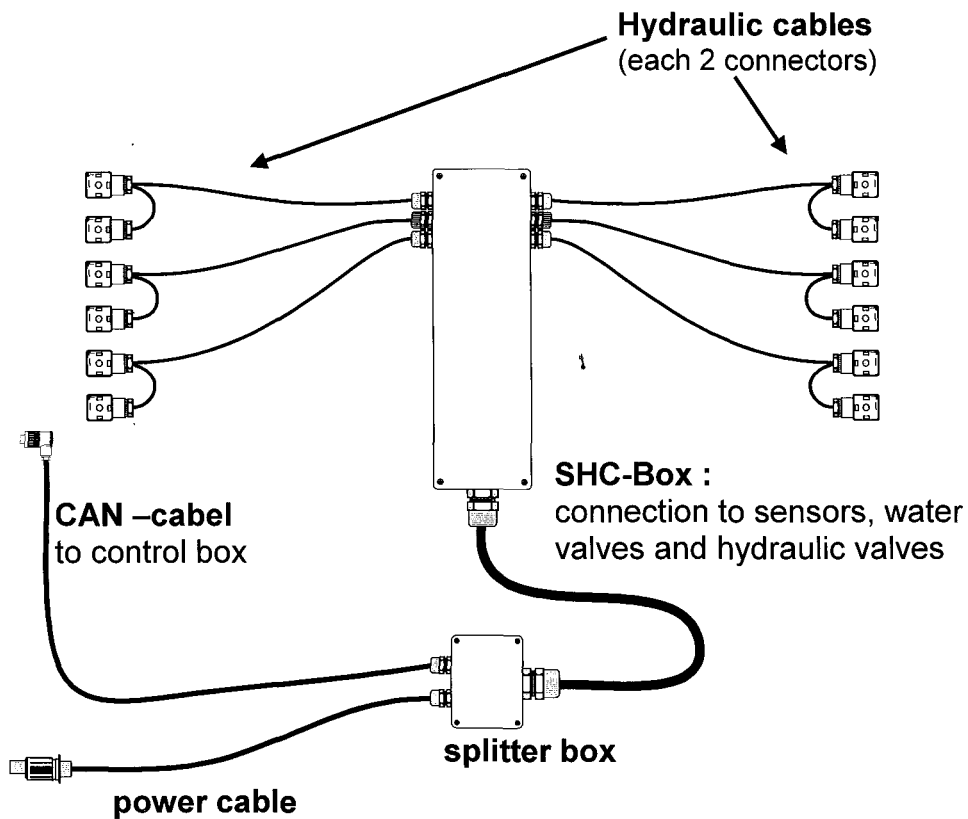

power cable (mounted sprayer: B0464973 / trailed sprayer: B0463673):

LEFT			CONNECTION			RIGHT		
connector	pos	contact	cable	colour	length	contact		connector
B0372273	+	B0345273	B0320973	brown	(5) m	B0345273		
B0372273	-	B0345273	B0320973	blue	(5) m	B0345273		

CAN-cable (mounted sprayer: B0463373 / trailed sprayer: B0463573):

<i>Bestiltes</i> LEFT			CONNECTION			RIGHT		
connector	pos	contact	cable	colour	length	contact	pos	connector
B0344673	1		B0320573	brown	(9,5) m	cut away		
B0344673	2		B0320573	red	(9,5) m	cut away		
B0344673	3	solder	B0320573	orange	(9,5) m	B0340173		B0340073
B0344673	4	solder	B0320573	yellow	(9,5) m	B0348373		
B0344673	5	solder	B0320573	green	(9,5) m	B0340173		B0340073
B0344673	6	solder	B0320573	blue	(9,5) m	B0348373		
B0344673	7	solder	B0320573	black	(9,5) m	B0340173		B0340073

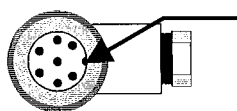

Nose always in this position

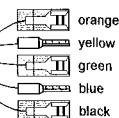
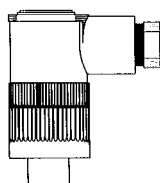

Bestiltes i Nieuw-Vennep

splitter box
pömskåp

Silvning sprungel =
INBEN ström på
controlbecks + SHC

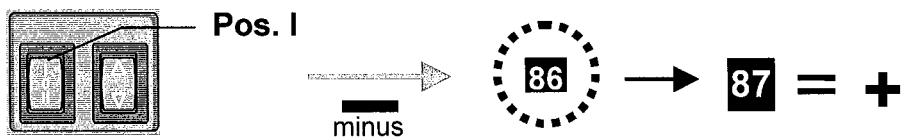
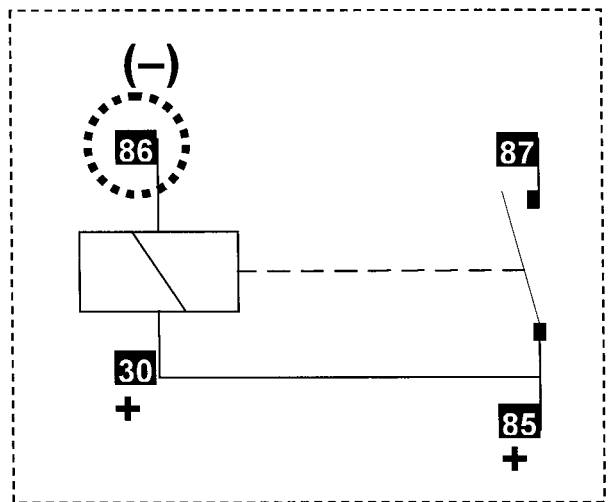
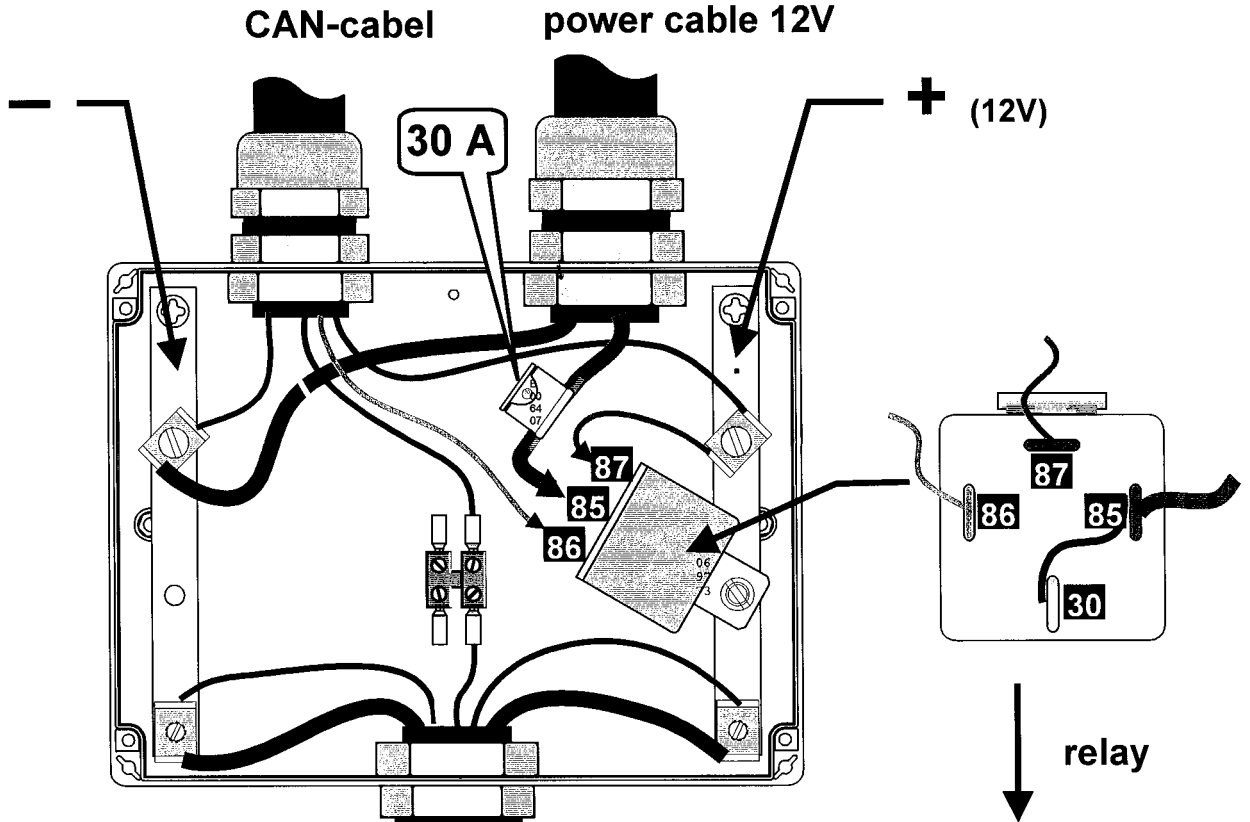

SHC - box connections

pai mas hira

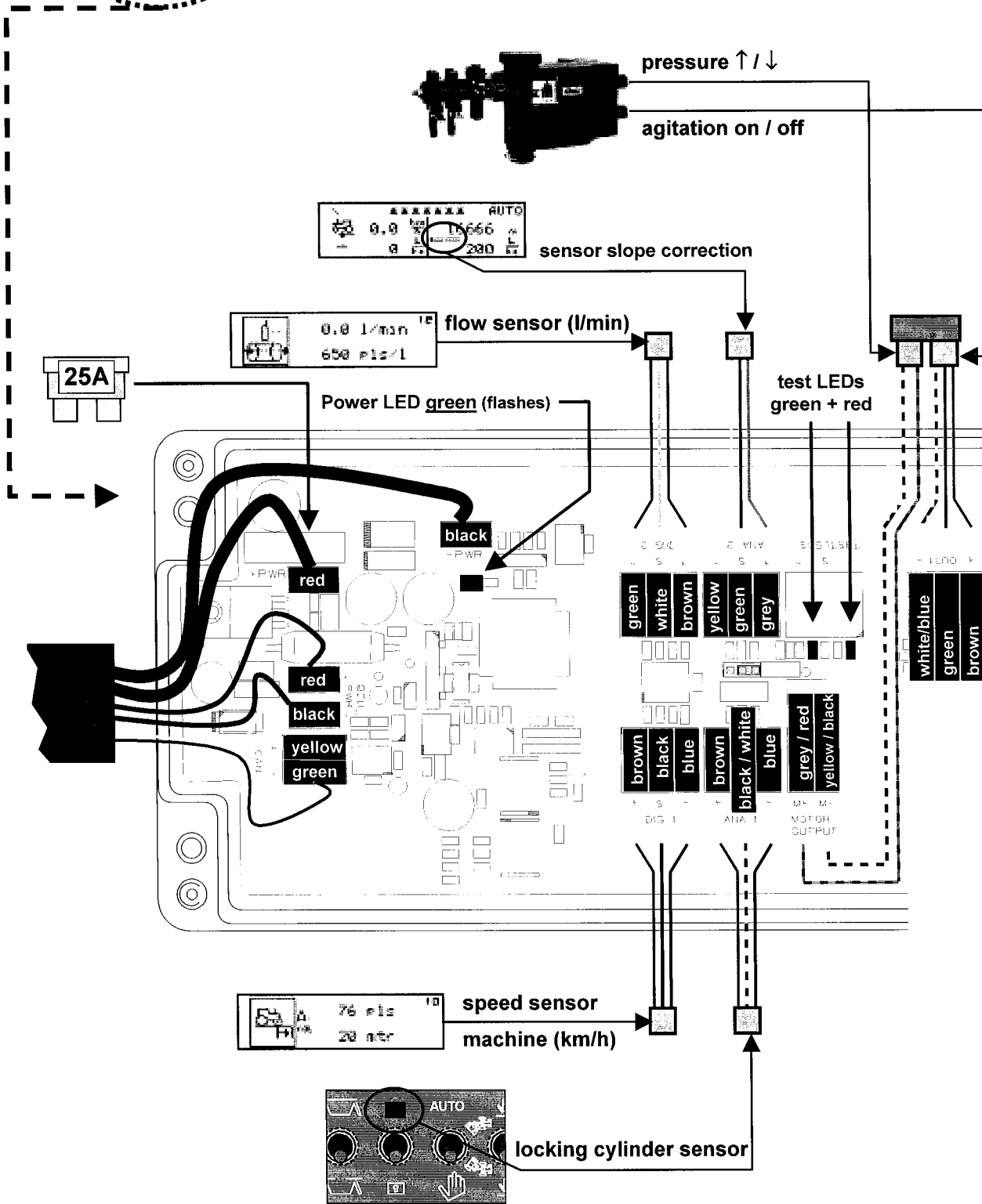
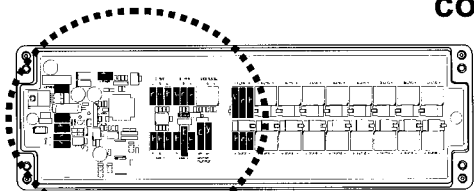

*Can bus hen illie make ... mult time of
Processor starts fault*

Position and connection of section cables

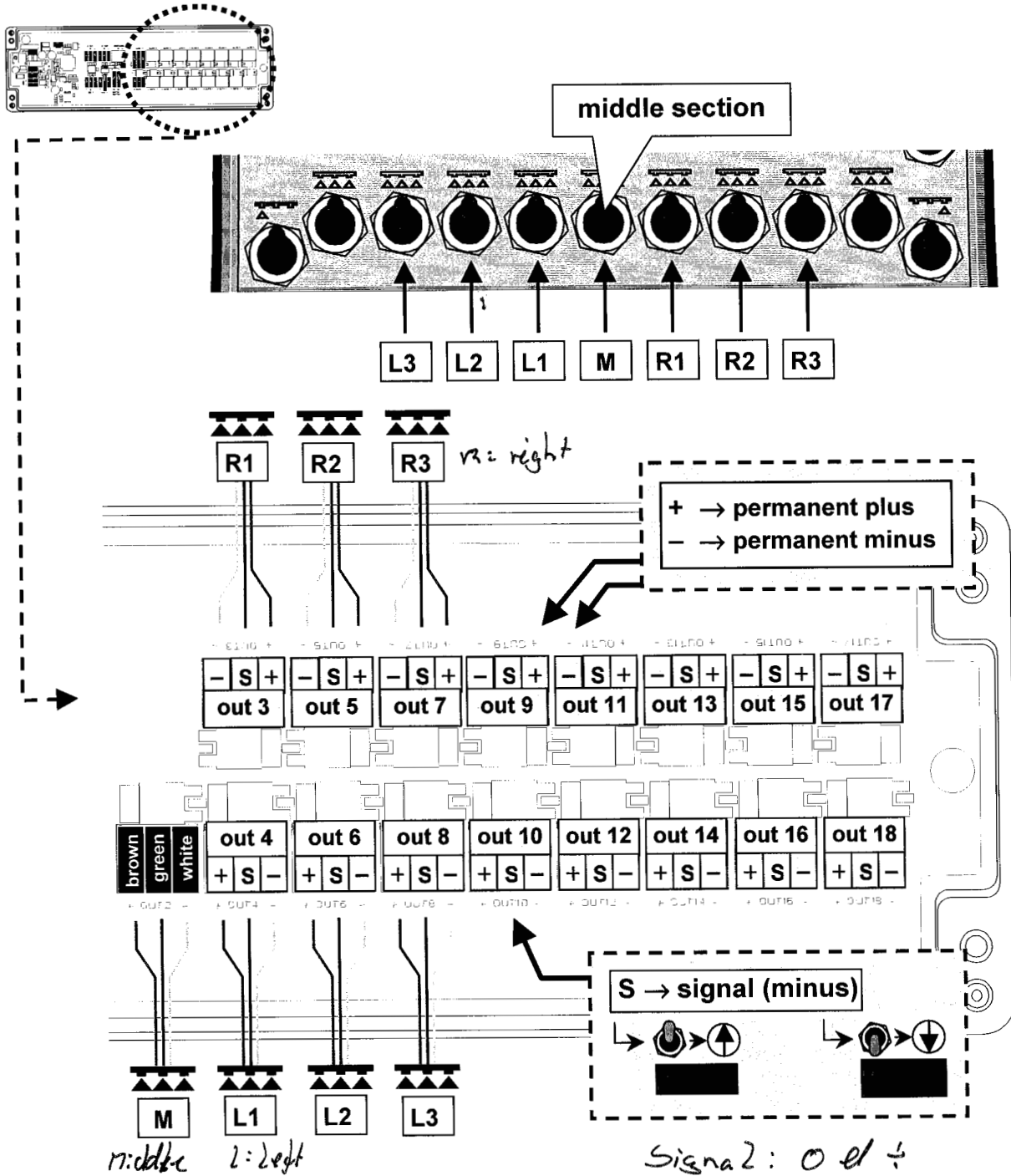

Relay at section valve motor:

Relay: spraying off

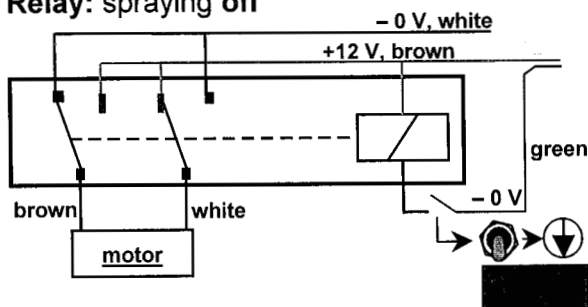

Relay: spraying on

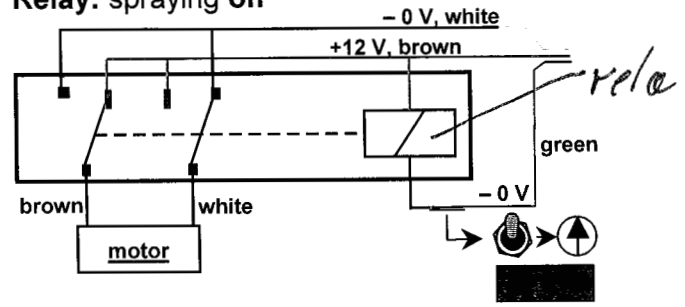

Order: Signal
service training

Position of hydraulic cables

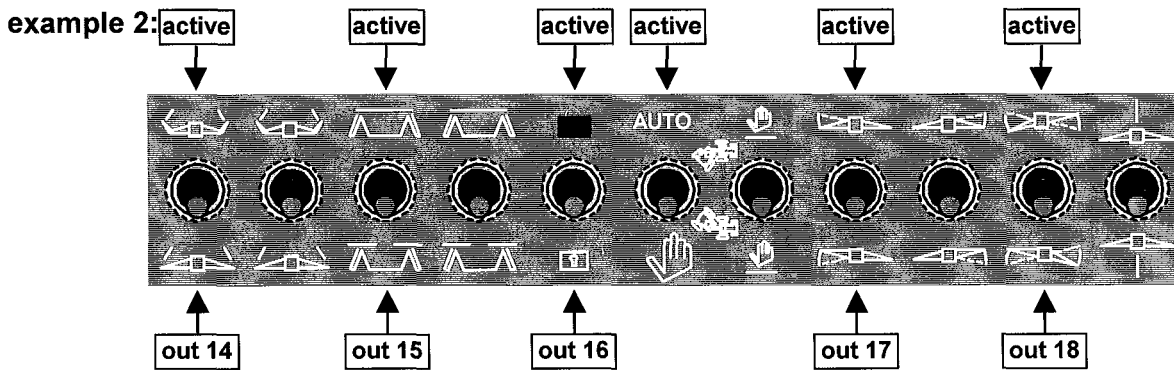
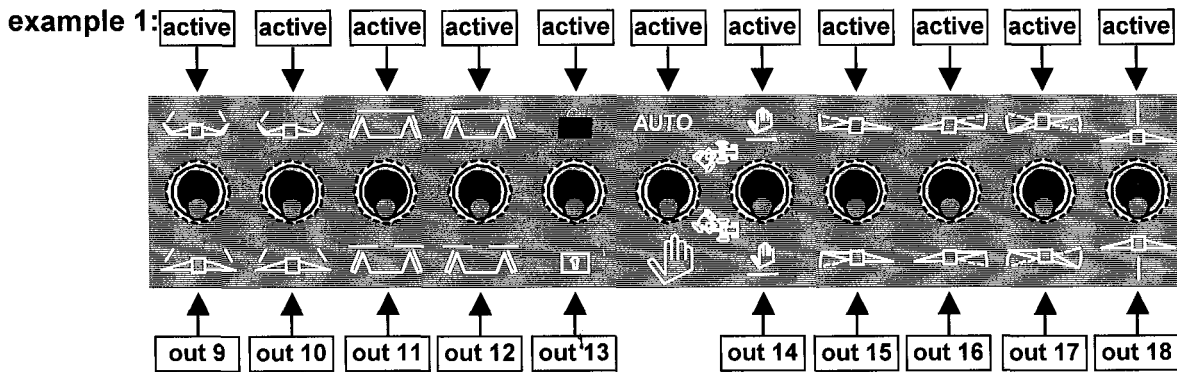

HC boom – standard:

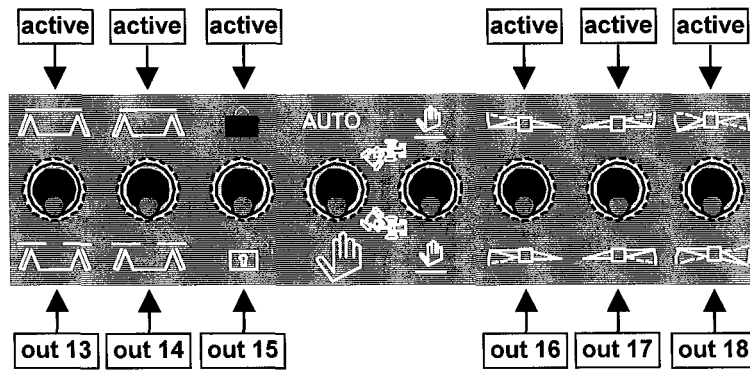

*Tel BJTED
 alle vande functie
 dra Vmael H
 start m. 18*

HC with oil circulation:

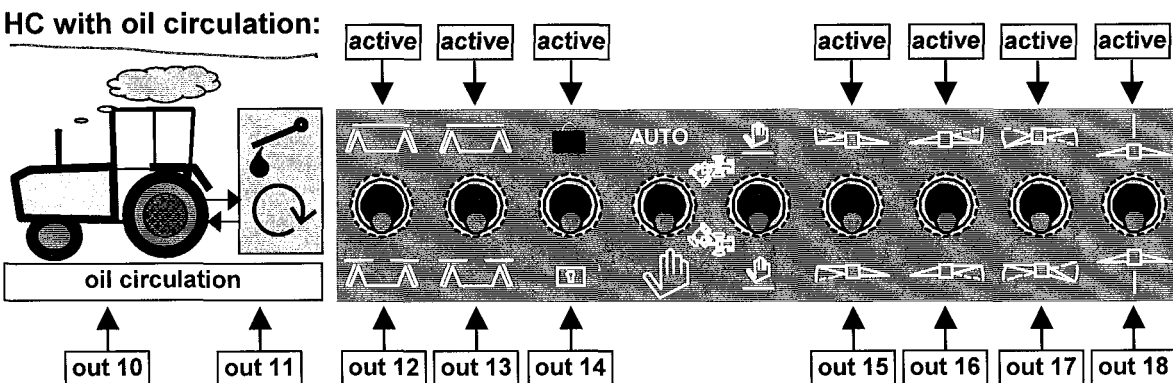

115

Connection of hydraulic cables

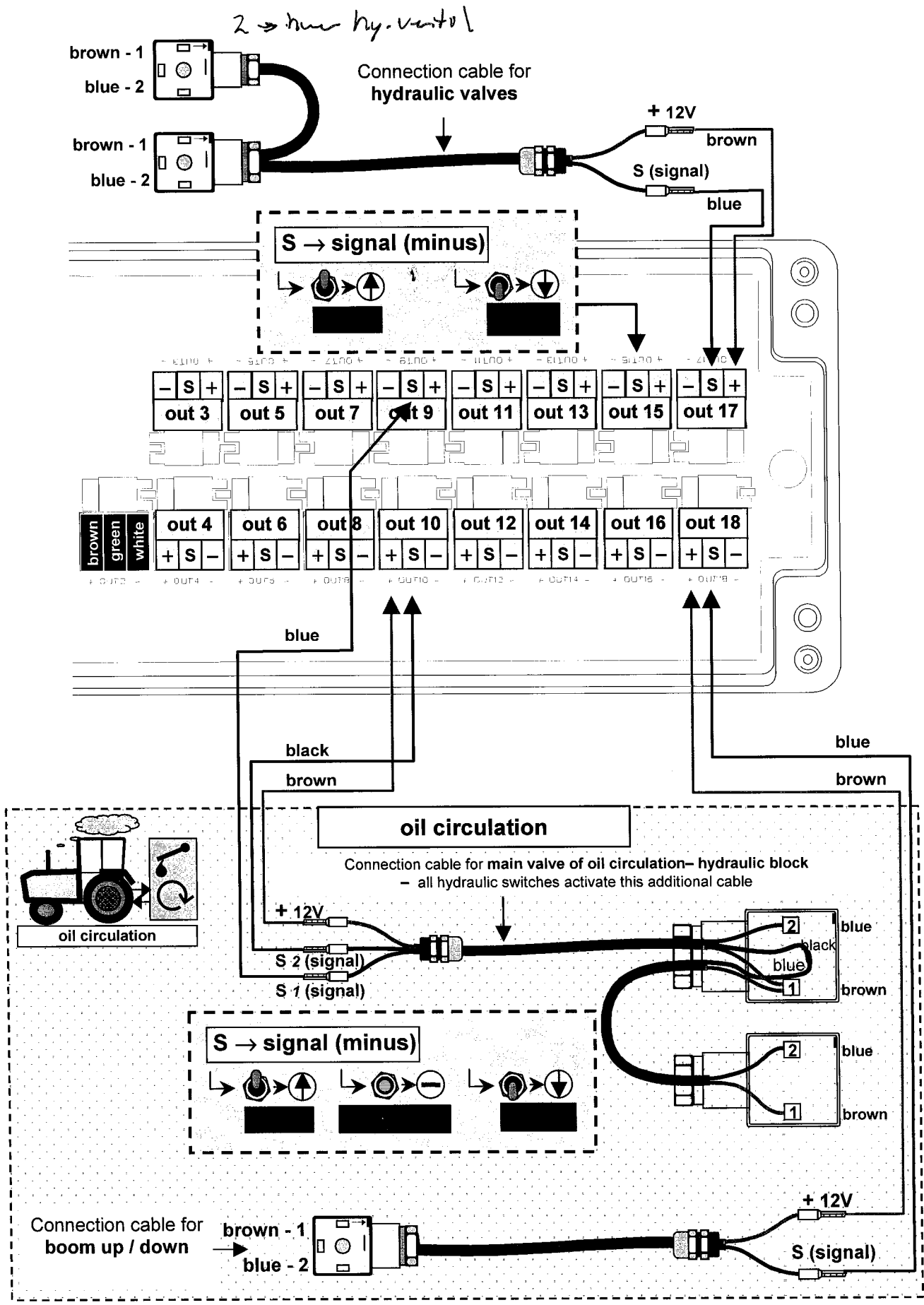

Hydraulic cables

Connection cable SHC – hydraulic valves:

- B0463273



LEFT			CONNECTION			RIGHT		
connector	pos	contact	cable	colour	length	contact	pos	connector
		B0348373	B0320273	brown	1 mtr	B0344773	1	B0145173
		B0348373	B0320273	blue	1 mtr	B0344773	2	B0145173
			CONNECTION			RIGHT		
			cable	colour	length	contact	pos	connector
			B0320273	brown	35 cm	B0348373	1	B0341373
			B0320273	blue	35 cm	B0348373	2	B0341373

Connection cable SHC – main valve oil circulation:

- Mounted sprayer: B0467273
- Trailed sprayer: B0467373

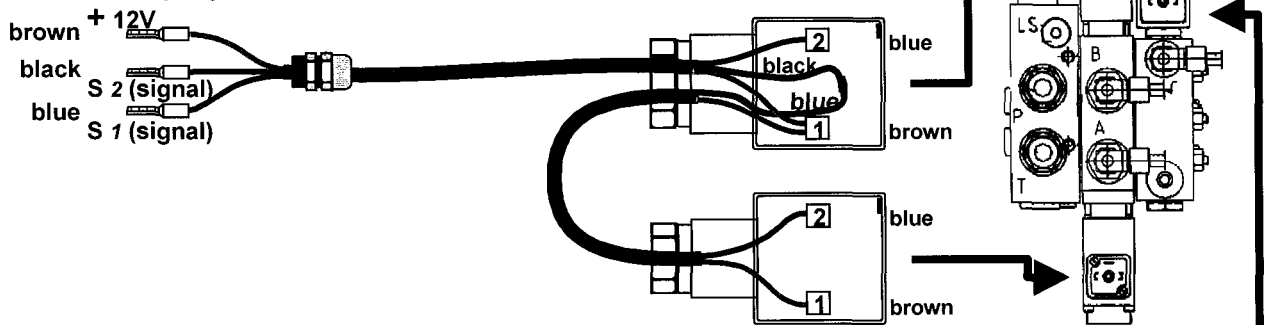

LEFT			CONNECTION			RIGHT		
connector	pos	contact	cable	colour	length	contact	pos	connector
		B0348373	B0320373	brown	(4) m	B0348373	1	B0145173
		B0348373	B0320373	blue	(4) m	B0344773	2	B0145173
		B0348373	B0320373	black	(4) m			
			CONNECTION			RIGHT		
			cable	colour	length	contact	pos	connector
			B0320273	brown	40 cm	B0348373	1	B0341373
			B0320273	blue	40 cm	B0348373	2	B0341373

Connection cable SHC – single valve oil circulation (boom up/down):

- mounted sprayer: B0467473
- trailed sprayer: B0467573



LEFT			CONNECTION			RIGHT		
connector	pos	contact	cable	colour	length	contact	pos	connector
		B0348373	B0320273	brown	(4) m	B0348373	1	B0341373
		B0348373	B0320273	blue	(4) m	B0348373	2	B0341373

Control box

Connector CAN - plug & speed / radar sensor (tractor)

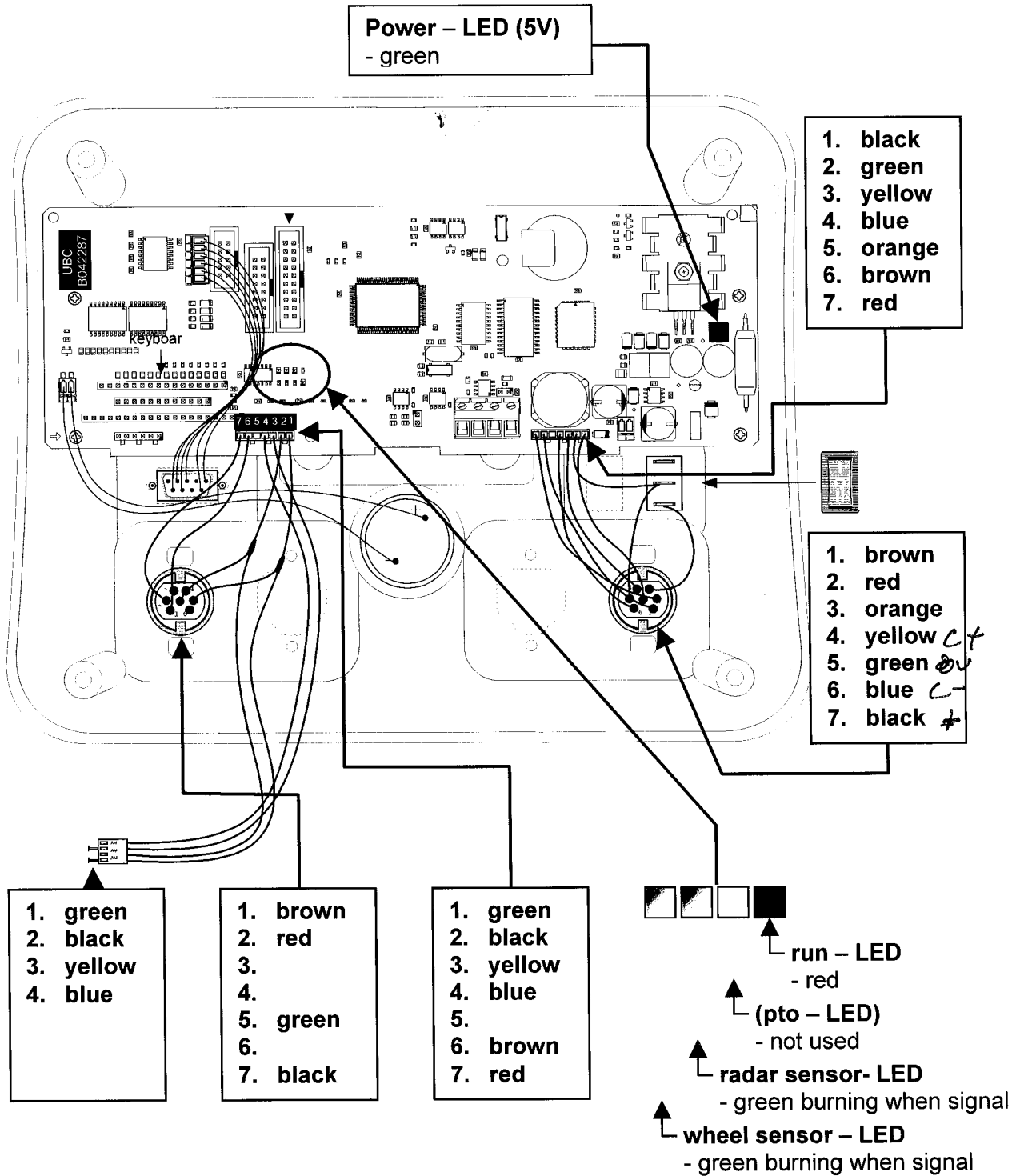



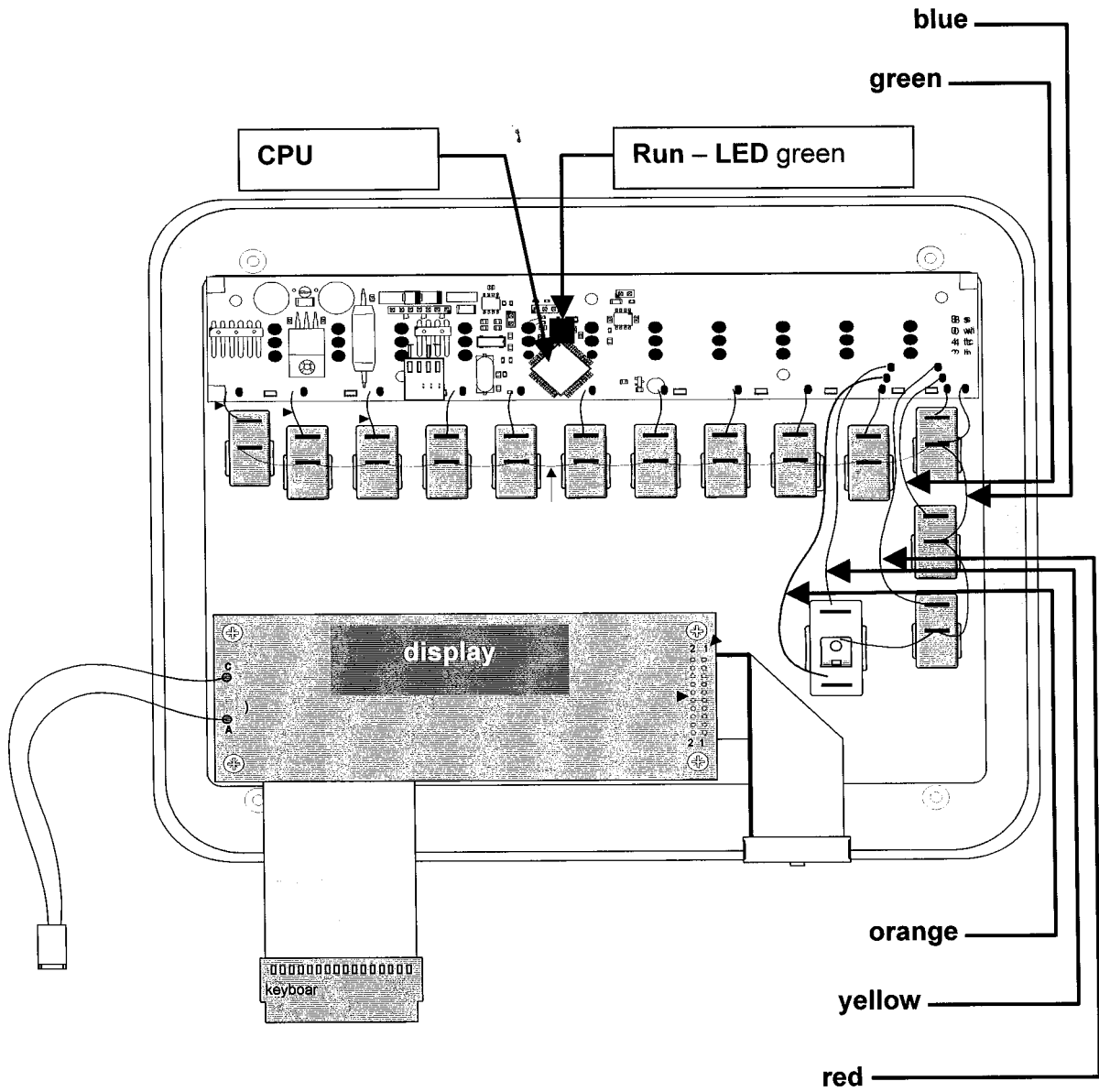



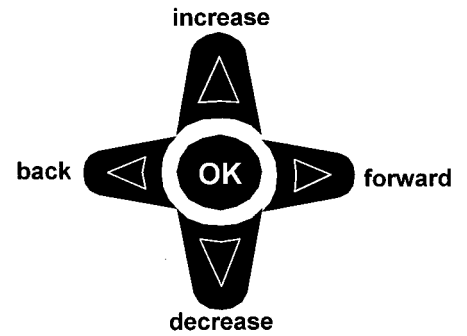



Front cover inside



Setup menu

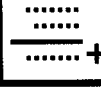

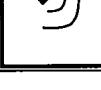

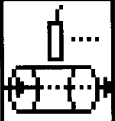
 <p>SETUP FUNCTIONS</p>	1	OK	
 	2		<ul style="list-style-type: none"> alarm signal
 <p>50 %</p>	3		<ul style="list-style-type: none"> contrast
 <p>100 %</p>	4		<ul style="list-style-type: none"> buzzer loudness
 <p>mtr</p>	5		<ul style="list-style-type: none"> setup „m“ or „ha“ for actual rest tank volume (pre selection for main screen)
 <p>2500 Ltr 200 Ltr</p>	6		<ul style="list-style-type: none"> max. tank volume alarm signal when tank volume is ... liter
 <p>10 L/Ha</p>	7		<ul style="list-style-type: none"> step for L/ha changes in main screen
 <p>0.0 Ha 0 Hltr</p>	8		<ul style="list-style-type: none"> area memory volume summary
 <p>Tractor Radar Machine</p>	9		<ul style="list-style-type: none"> kind / position of speed sensor
 <p>76 Pls 20 mtr</p>	10		<ul style="list-style-type: none"> impulses speed sensor distance for shown impulses
 <p>130 pls</p>	11		<ul style="list-style-type: none"> impulses radar sensor (only shown when radar is selected in „9“)

	0.0 l/min ¹² 650 pls/l
---	--------------------------------------

- actual flow in liter/min
- impulses per liter (calibration flow meter)

 sim	6.0 km/h ¹³
--	------------------------

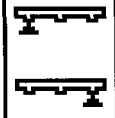
- simulation speed (if speed sensor doesn't work and for first time period)

	 ¹⁴
---	---

- Border nozzles (yes / no)

	L5= 0.00 m ¹⁵ L4= 0.00 m L3= 1.00 m L2= 1.00 m
---	--

- working width of each section (left 5 to left 2)

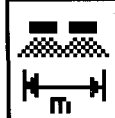
	L1= 1.00 m ¹⁶ M= 1.50 m R1= 1.00 m
---	---

- working width of each section (left 1 + middle + right 1)

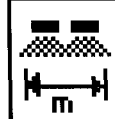
	R2= 1.00 m ¹⁷ R3= 1.00 m R4= 0.00 m R5= 0.00 m
--	--

- working width of each section (right 2 to right 5)
- also 7 sections + 0 border nozzle

	1 --- ¹⁸ 2 --- 3 --- 4 ---
---	--

- Nozzle input

	1= 10 Q/s ¹⁹ 2= 10 Q/s 3= 10 Q/s 4= 10 Q/s
---	--

- parameters for pressure regulator (only used in combination with 2 way section valves)

	C _{100 %} ²⁰
---	----------------------------------

- quick adjust for flow meter

	P Q sensor ²¹
---	--------------------------

- flow meter or pressure sensor (Q = volume / P = pressure)

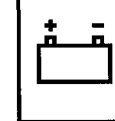
	12.6 V (BC) ²² 12.7 V (IMP)
---	---

- voltage control box
- voltage SHC - box

	19:56:41 ²³ 18/09/02
---	------------------------------------

- time
- date

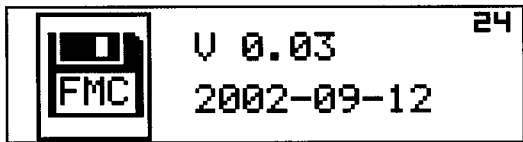

- software version control box
- date of version

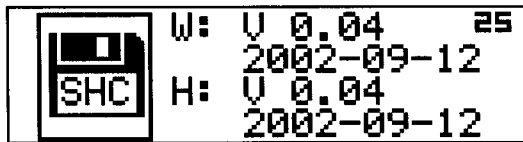

- software version / date SHC - Box **water**
- software version / date SHC - Box **hydraulics**

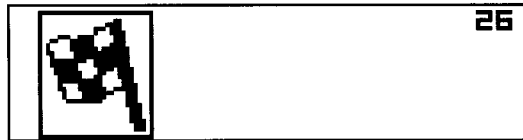

- end



- press  for pin



Main settings:
Adjusted by factory

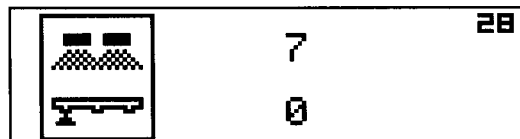

- number of sections
- number of border nozzles

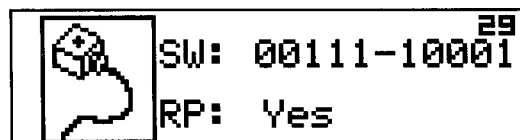

- activated hydraulic switches
- oil circulation (**Yes / No**)

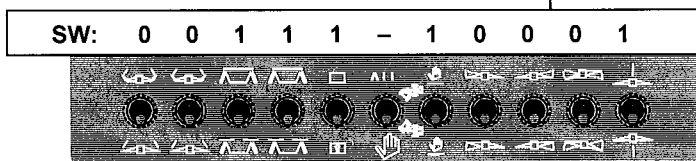

For settings see the following page

Activate hydraulic switches

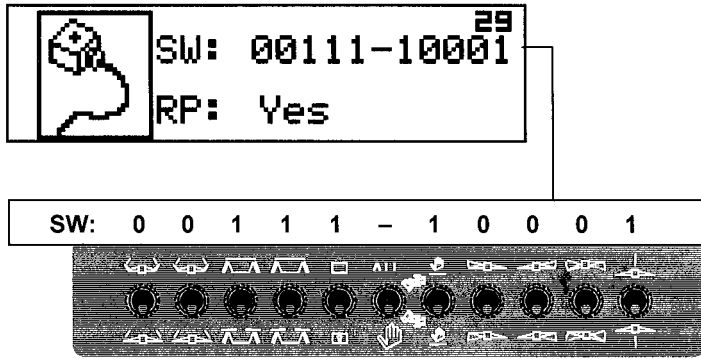

Change:

↳ **OK** → First line is flashing

- Move **active** switches up till „1“ is shown in display
- Move **inactive** switches down till „0“ is shown in display

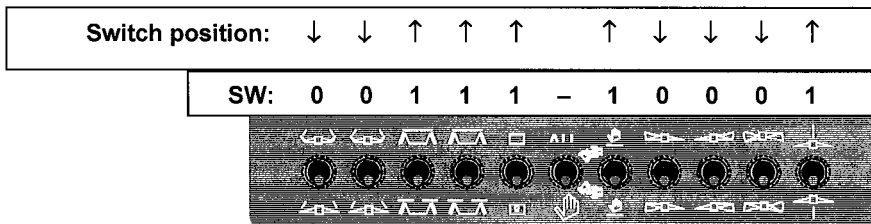

↳ **OK** → store

Setup menu continued from last page

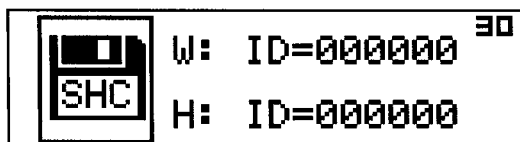

- pcb water ID-No. (self installed)
- pcb hydraulics ID-No. (self installed)

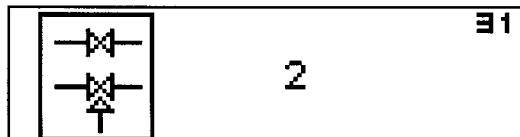

- Section valves **2-way** or **3-way**
→ section valves with calibrated return flow are always **3-way valves**

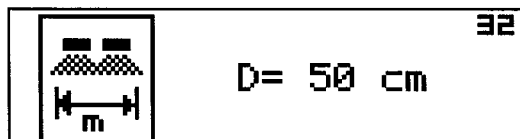

- nozzle distance **50cm / 25cm**

	bar P	102 922 cnt	33
		0.0 10.3 bar	

- parameters for pressure sensor
(use here shown parameters)

	No reg:	0.8 %	34
	P zone:	6 %	
	T on:	50 ms	
	T off:	150 ms	

- parameter „P1“ for pressure regulator
ERM - regulator:
use here shown parameters

	Rev. D:	3 %	35
	P zone:	13 %	
	T on:	50 ms	
	T off:	100 ms	

- parameter „P2“ regulator
ERM - regulator:
use here shown parameters

		1 sec	36
---	--	-------	----

- time to use simulation speed when starting spraying on

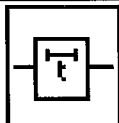
	SP:	50 %	37
	FL:	20 %	
	PR:	50 %	
	AL:	5 sec	

- Parameters for sensors
use here shown parameters
- SP = speed sensor, FL= flow meter, PR = pressure sensor, AL= period for alarm

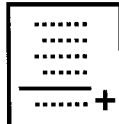
		0 Ha	38
		0 Ltr	
		0:00 h:m	

- summary for service people:
area, volume, hours

	KPD:	50.0 mm	39
	KPL:	0 cm	

- parameters for filling / cleaning the hoses and spray lines (here example)

	PD1:	25.0 mm	40
	PL1:	0 cm	
	PC1:	0.00 ltr	

- parameters for filling / cleaning the hoses and spray lines (here example)

	PD2:	25.0 mm	41
	PL2:	0 cm	
	PC2:	0.83 ltr	

- parameters for filling / cleaning the hoses and spray lines (here example)

	SD1:	13.0 mm	42
	SD2:	20.0 mm	

- parameters for filling / cleaning the hoses and spray lines (here example)

	SL5:	0 cm	43
	SL4:	0 cm	
	SL3:	0 cm	
	SL2:	0 cm	

- parameters for filling / cleaning the hoses and spray lines (here example)

	SL1:	0 cm	44
	SM:	0 cm	
	SR1:	0 cm	

- parameters for filling / cleaning the hoses and spray lines (here example)

SHC – box tests

Standard:

→ green and red test LED are burning.

- This means also:
If there is a single cable only connected at position "S" of the test position
→ green and red LED are burning.

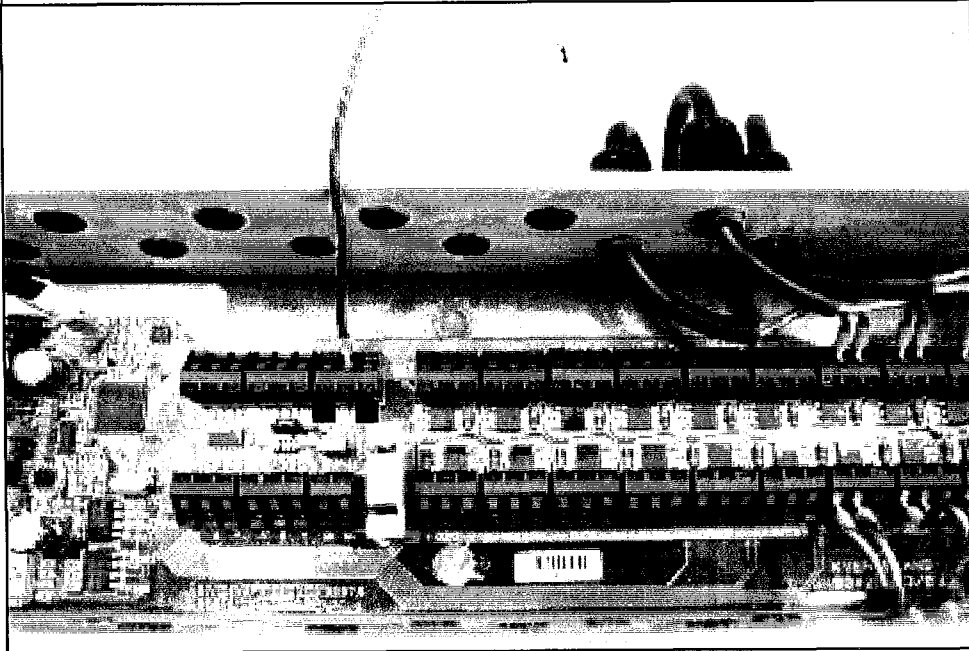

+ (plus 12V) test:

- connect a single cable to „S“ at test position and to „+“ at an other position
→ red LED is burning

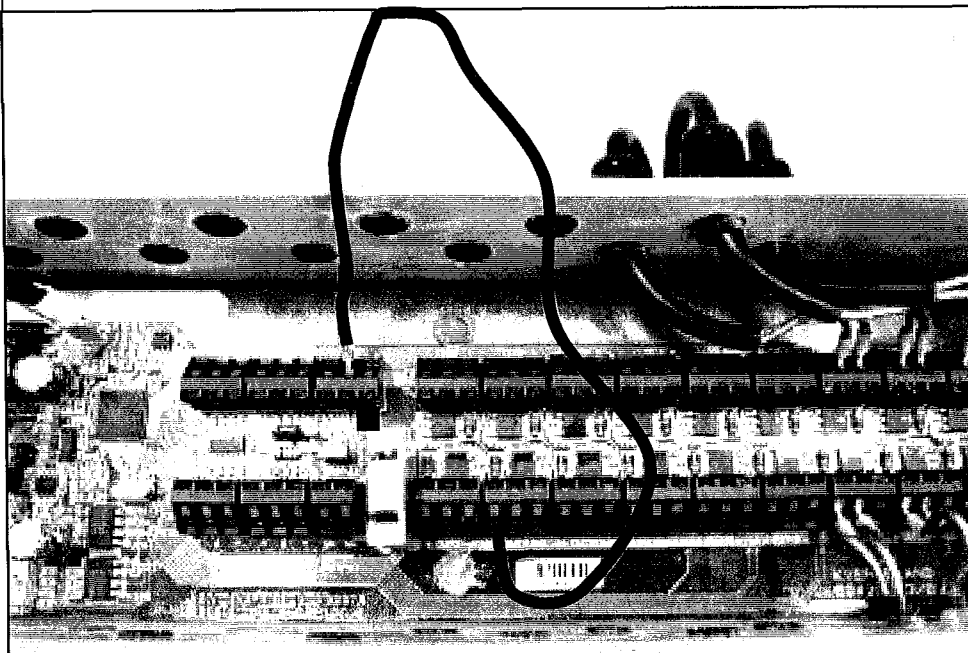

– (minus) test:

- connect a single cable to „S“ at test position and to „–“ at an other position
→ green LED is burning

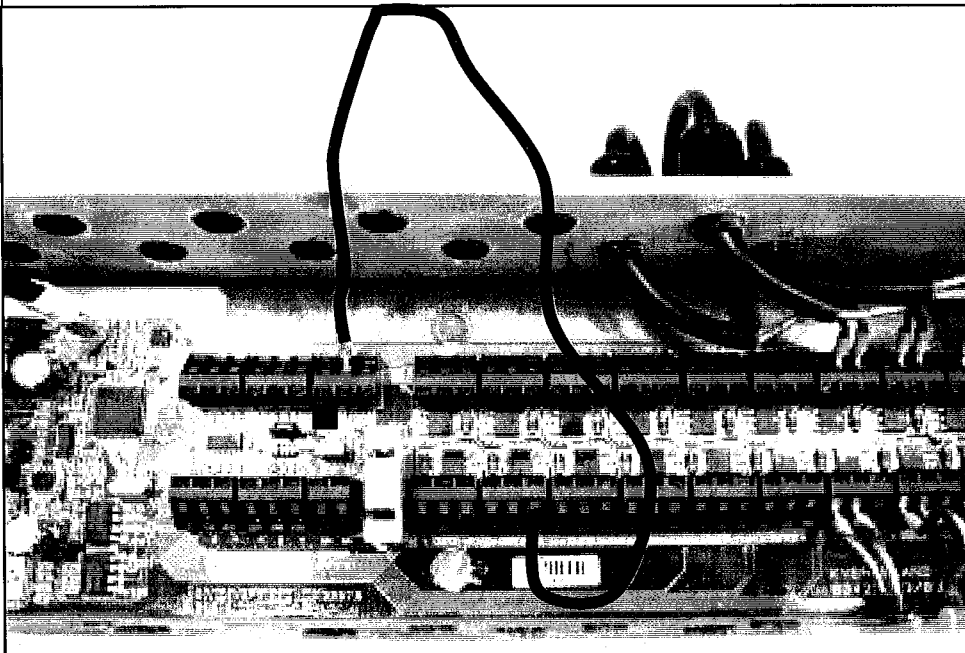

„S“ signal test:

- connect a single cable to „S“ of test position and „S“ of an other position and activate additionally the according switch of the other position.

→ **green LED** is burning while the switch is activated because the signal is based on minus (-).

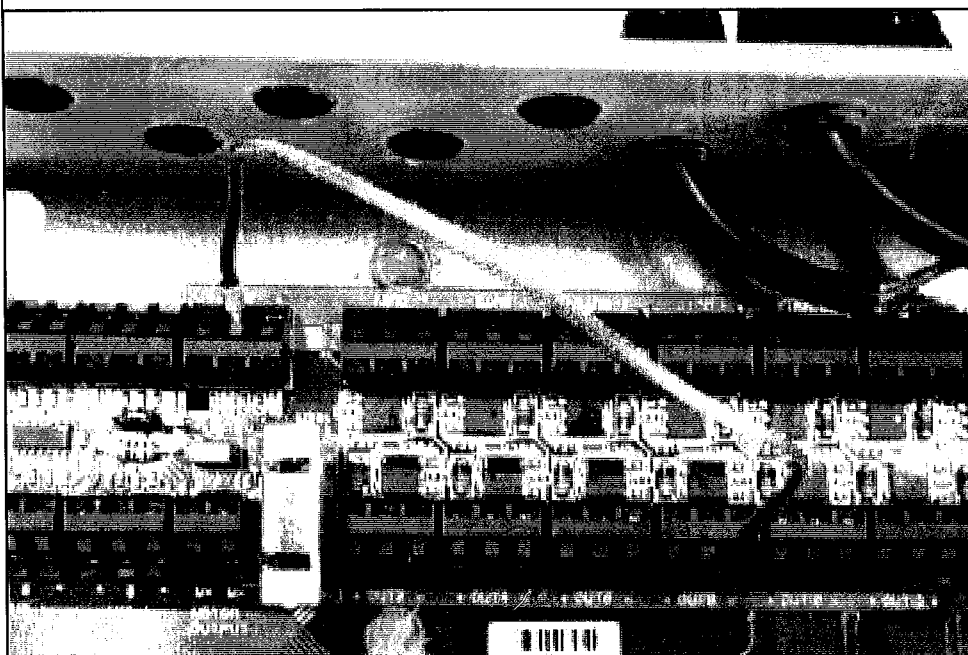

Cable and sensor test

Cable test

Example hydraulic cable:

Disconnect the single cable from the working position and connect it to „S“ of the test position. Connect position 1 and 2 of the plug to each other with a separate single cable (bridge).

→ **red LED is burning,**
because + (plus) is connected to the signal cable

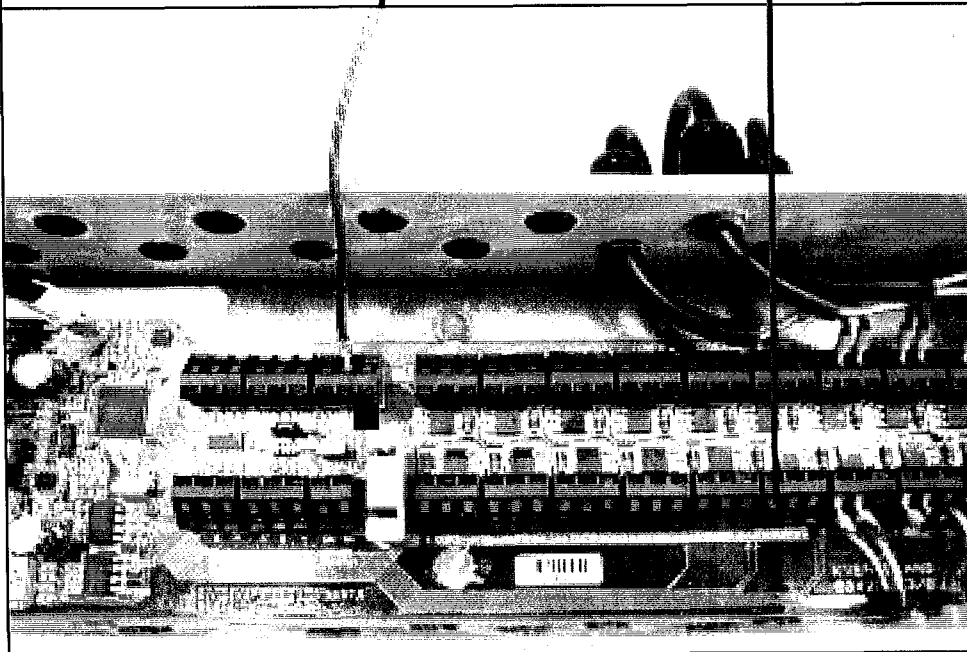
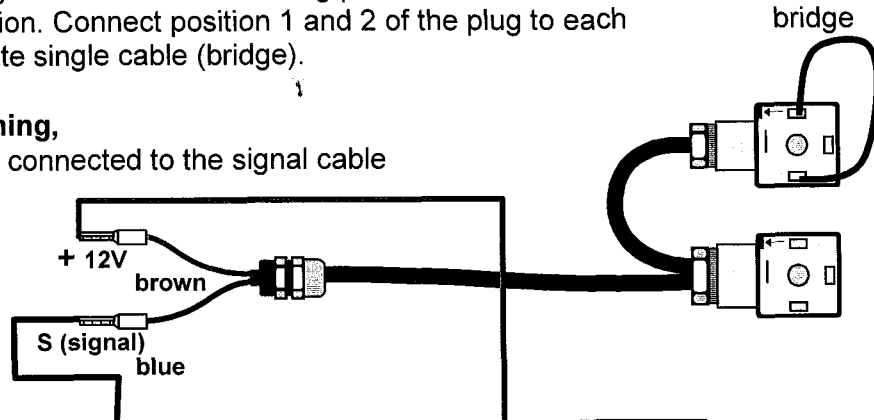

Speed sensor (machine) and Locking sensor test

The **signal is + (plus 12V)** when the **speed sensor** is in contact to **metal** in a distance of less than **4 mm**. In other cases the signal is neutral.

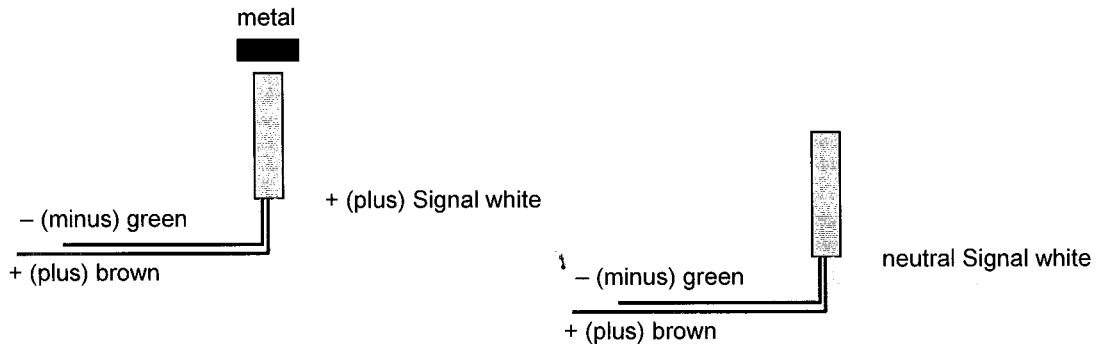

Connect the signal cable (white) to "S" of the test position.

In contact to metal:

→ **red LED is burning**

Not in contact to metal:

→ **green and red LED are burning**

Test the **locking sensor** in the same way, but keep care, the locking sensor does only react to a **magnetic** and not to simple metal.

Flow sensor test

The **signal changes** from **+ (plus 12V)** to **neutral** (and back) when **metal moves along the sensor**.

This means there are two different cases:

From first contact till second contact +12V

From second contact till third contact neutral and so on.

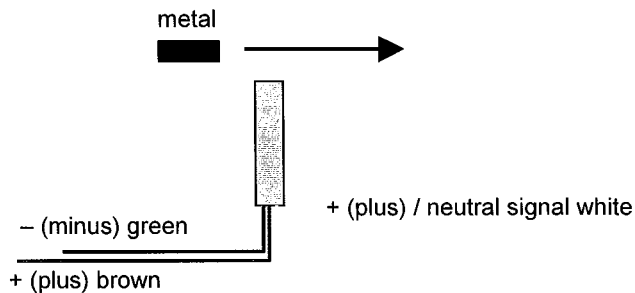

Connect the signal cable (white) to "S" of the test position.

Move metal along the flow sensor:

→ **red LED is burning till**

Move metal along the flow sensor for a second time:

→ **green and red LED are burning till**

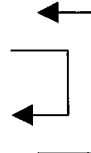

Special tools

Order to after sales service of
Kverneland sales company or Kverneland - RAU importer

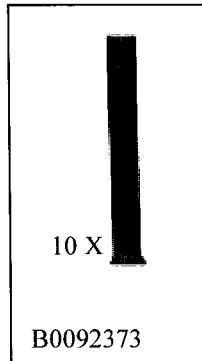
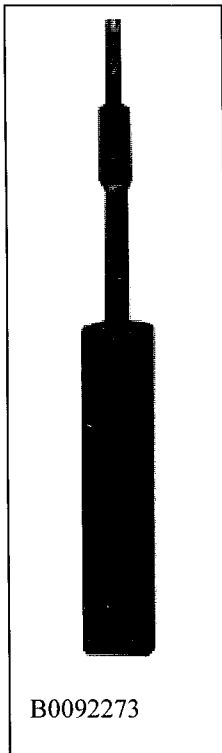
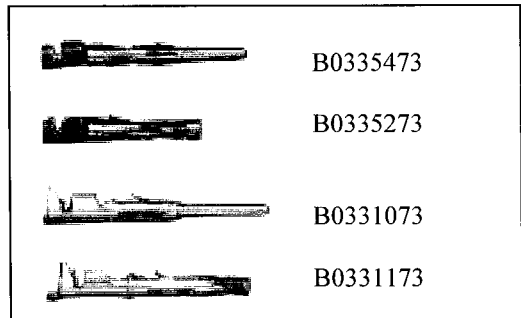
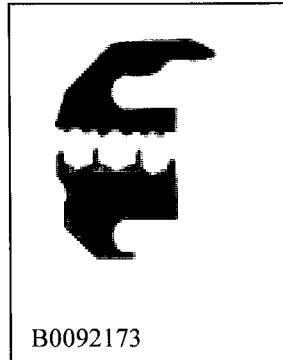
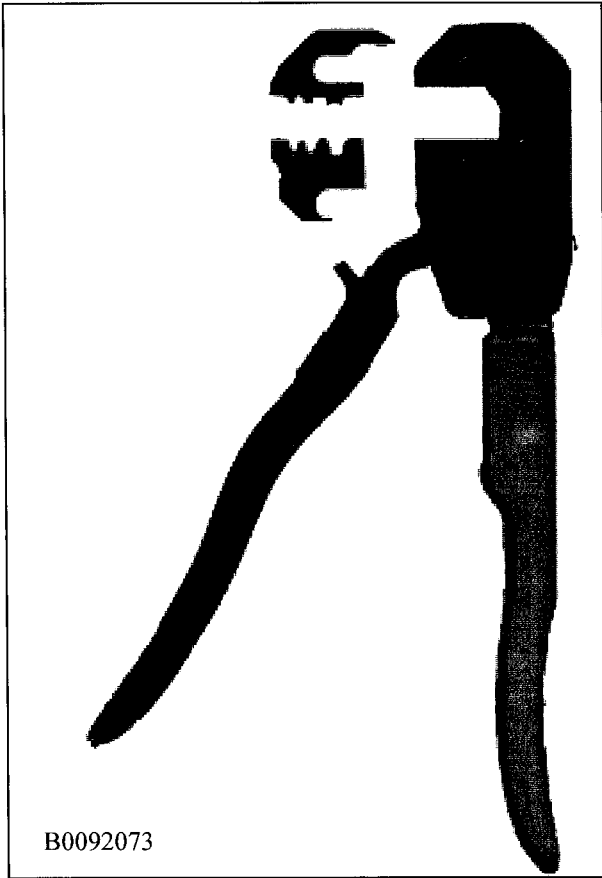

Plugs

Order to after sales service of
Kverneland sales company or Kverneland - RAU importer

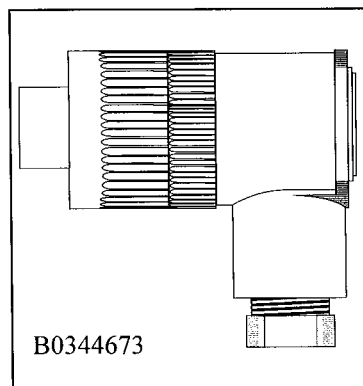
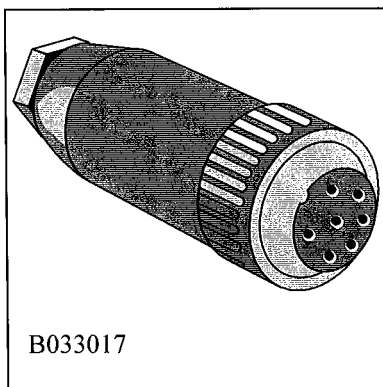
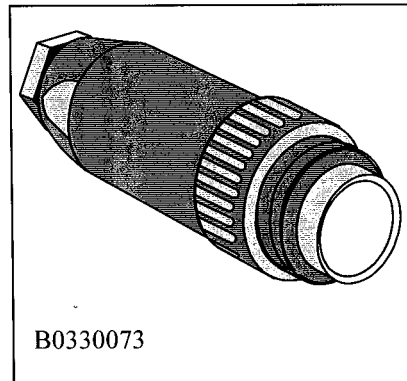
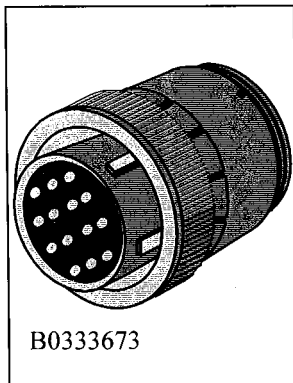
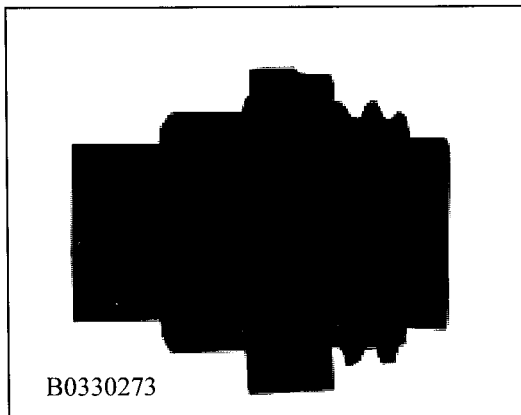
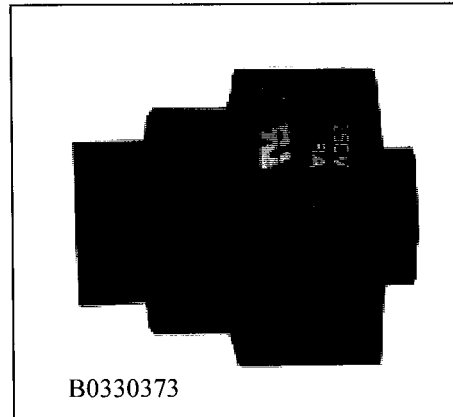
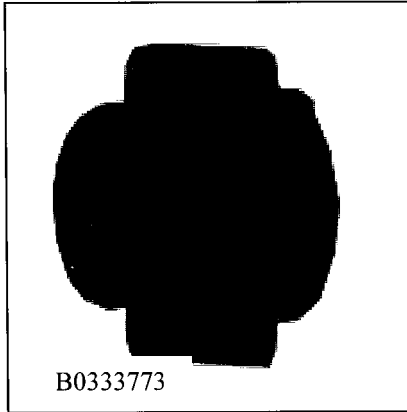

List special tools and special material

Order to after sales service of
Kverneland sales company or Kverneland - RAU importer

Tools		
Qty	part.- no.	description
1	B0092073	Amp Certilock crimping tool 169400-0 + die set for amp/amphenol contacts 169414-0
1	B0092173	Extra die set amp cable shoes R/B/Y 169404-0
1	B0092273	Extraction tool amphenol contacts 725840-1
1	B0092373	Set tips extraction tool 10 pieces 725841-1

1

Basic set single: B0532873		
Qty	part.- no.	description
1	B0330373	Chassis part female amp 7 pole
1	B0330273	Chassis part male amp 7 pole
1	B0330173	Cable part female amp 7 pole
1	B0330073	Cable part male amp 7 pole
14	B0331173	contact 0.5-1.5 mm female amp
14	B0331073	contact 0.5-1.5 mm male amp
1	B0333773	Chassis part female amphenol 14 pole
1	B0333673	Cable part male amphenol 14 pole
14	B0335273	contact 0.5-1.5 mm female amphenol
14	B0335473	contact 0.5-1.5 mm male amphenol

Basic set double: B0532973		
Qty	part.- no.	description
2	B0330373	Chassis part female amp 7 pole
2	B0330273	Chassis part male amp 7 pole
2	B0330173	Cable part female amp 7 pole
2	B0330073	Cable part male amp 7 pole
28	B0331173	contact 0.5-1.5 mm female amp
28	B0331073	contact 0.5-1.5 mm male amp
2	B0333773	Chassis part female amphenol 14 pole
2	B0333673	Cable part male amphenol 14 pole
28	B0335273	contact 0.5-1.5 mm female amphenol
28	B0335473	contact 0.5-1.5 mm male amphenol

Additional set chassis part female amp 7 pole: B0533073		
Qty	part.- no.	description
5	B0330373	Chassis part female amp 7 pole
35	B0331173	contact 0.5-1.5 mm female amp

Additional set chassis part male amp 7 pole: B0533173		
Qty	part.- no.	description
5	B0330273	Chassis part male amp 7 pole
35	B0331073	contact 0.5-1.5 mm male amp

Additional set cable part female amp 7 pole: B0533273		
Qty	part.- no.	description
5	B0330173	Cable part female amp 7 pole
35	B0331173	contact 0.5-1.5 mm female amp

Additional set cable part male amp 7 pole: B0533373		
Qty	part.- no.	description
5	B0330073	Cable part male amp 7 pole
35	B0331073	contact 0.5-1.5 mm male amp

Additional set chassis part female amphenol 14 pole: B0533473		
Qty	part.- no.	description
5	B0333773	Chassis part female amphenol 14 pole
70	B0335273	contact 0.5-1.5 mm female amphenol

Additional set cable part male amphenol 14 pole: B0533573		
Qty	part.- no.	description
5	B0333673	Cable part male amphenol 14 pole
70	B0335473	contact 0.5-1.5 mm male amphenol

Additional set chassis part female squared amp 7 pole: B0538773		
Qty	part.- no.	description
5	B0344673	Cable part squared female amp 7 pole
35	B0331173	contact 0.5-1.5 mm female amp

Special part HC – boom

Folding in / out

Example: pressure restriction valves right boom sections

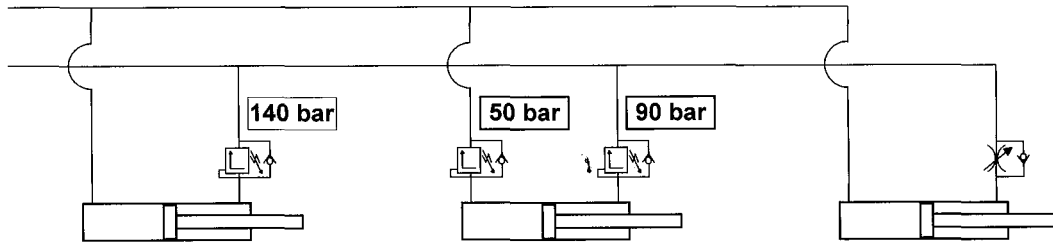

Folding in (cylinders will be moved to longest length):

— Pressure — Return flow

1. Pressure less than 90 bar (→ till first cylinder is at end position)

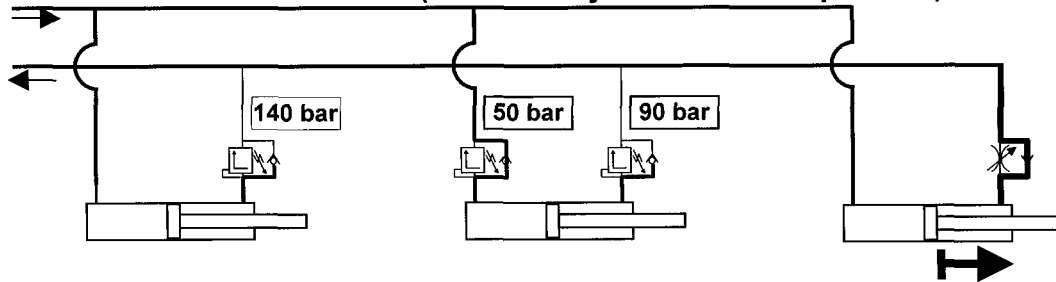

2. Pressure between 90 bar and 140 bar (→ till second cylinder is at end position)

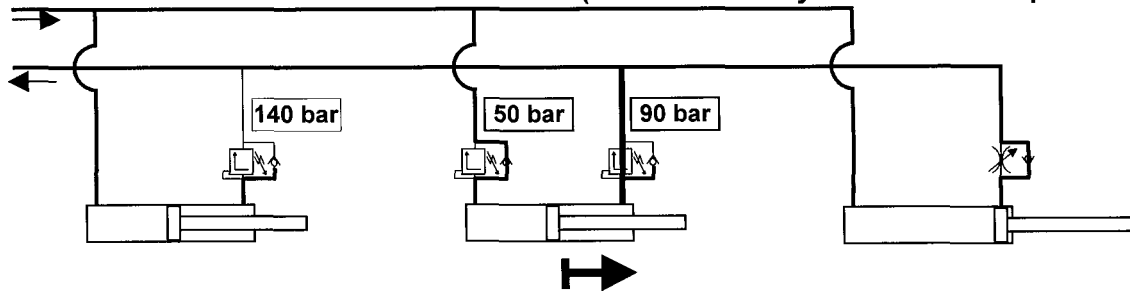

3. Pressure more than 140 bar

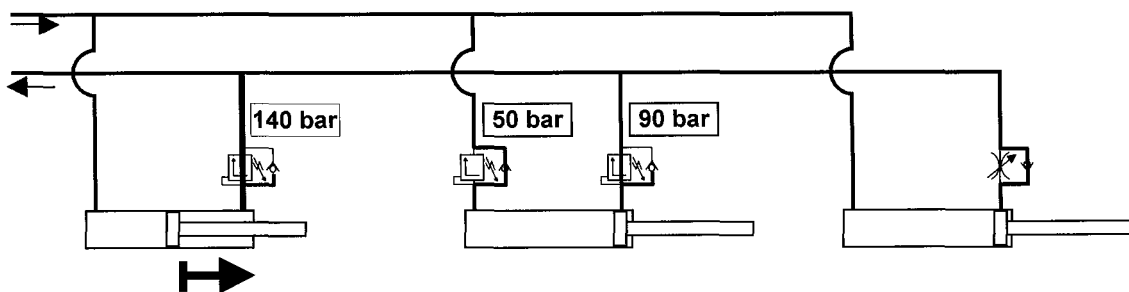

Folding out (cylinders will be moved to shortest length):

—— Pressure —— Return flow

1. Pressure less than 50 bar (→ till cylinder is at end position)

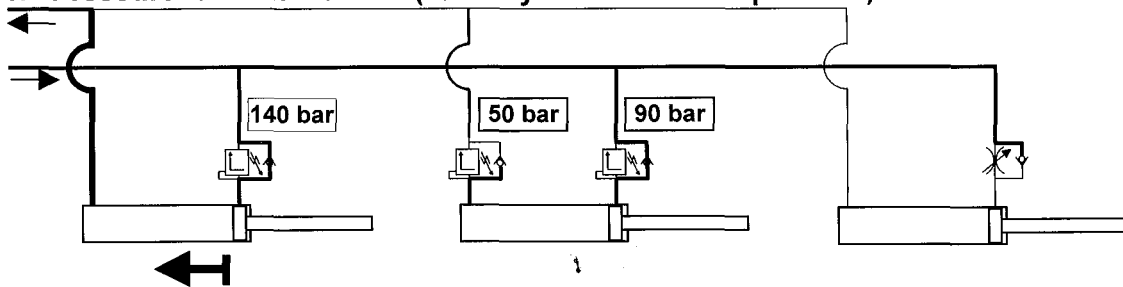

2. Pressure between 50 bar and restrictor resistance of last cylinder (→ till second cylinder is at end position)

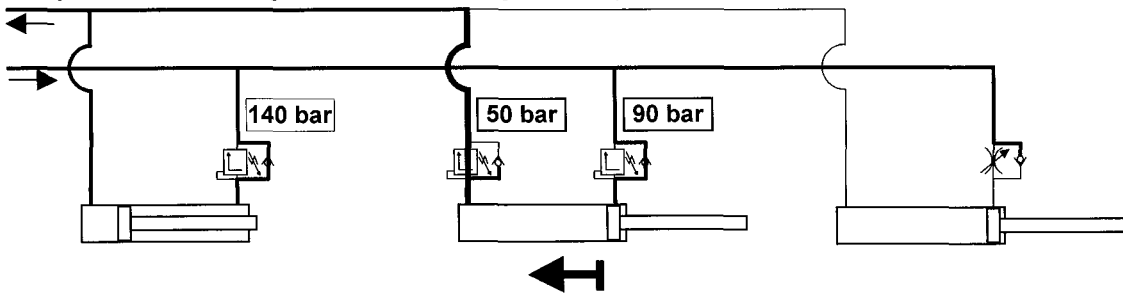

3. Pressure more than restrictor resistance of last cylinder

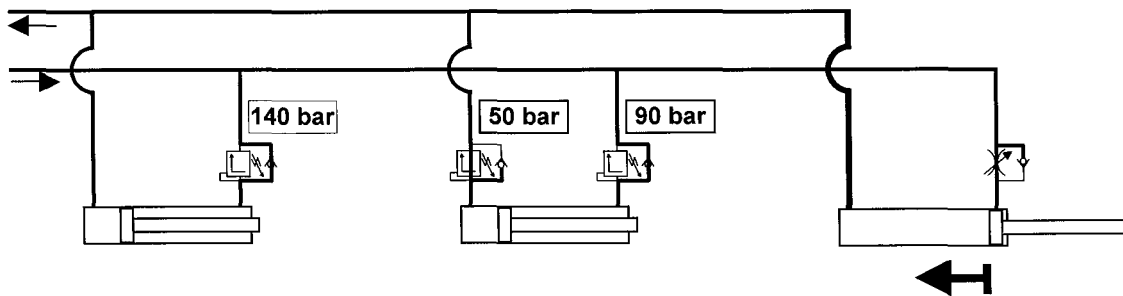

Notice

1

Notice

1

Notice

1